

SCE825K01 - Rigid Cable Rack Splice for 1.50" and 2.00" Stringers

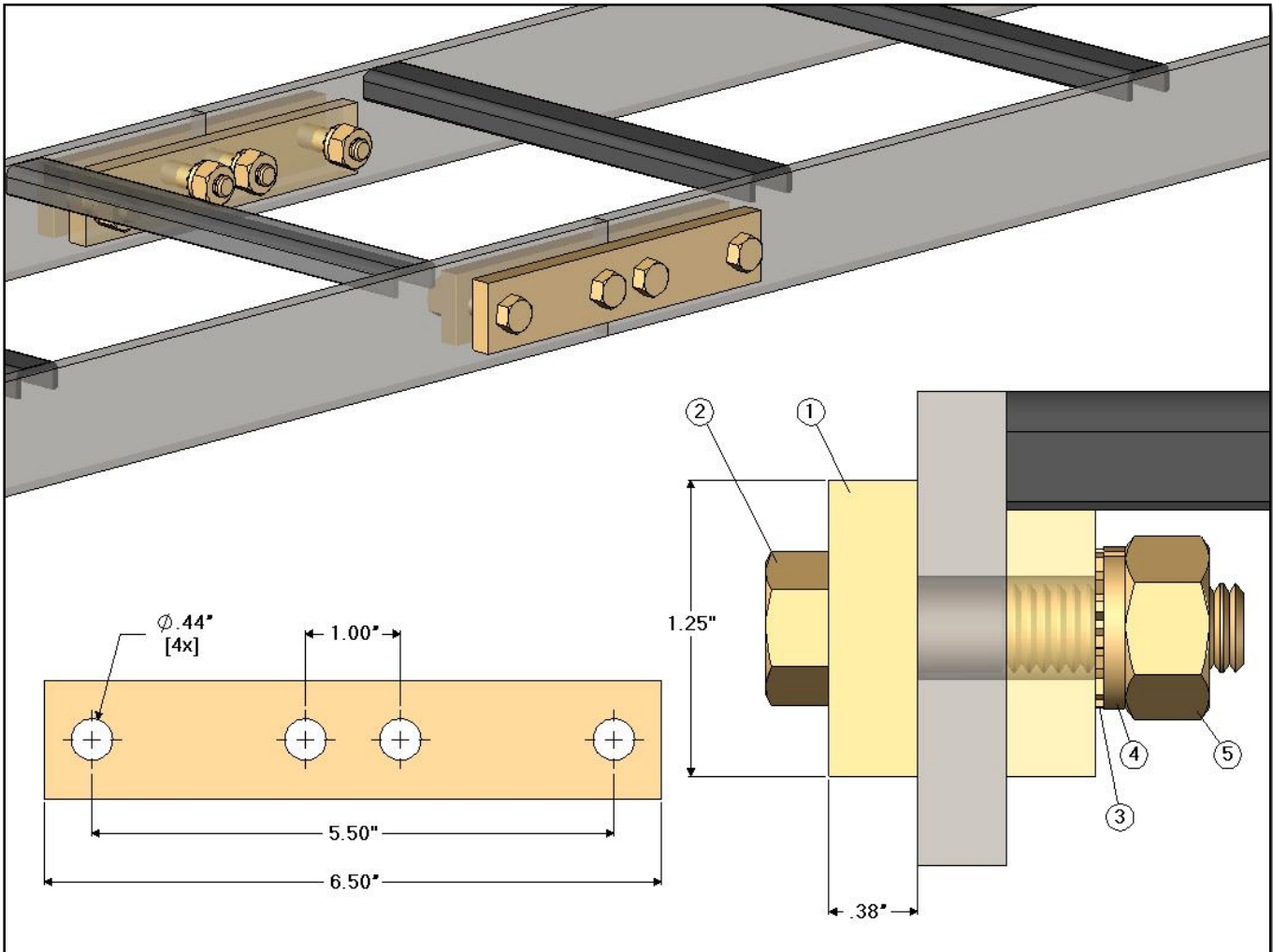

**SCE825K01 - Rigid Cable Rack Splice
for 1.50" and 2.00" Stringers**

Item	CSF P/N#	QTY	Description
1	SCE650B	4	Splice Bar
2	HH1006	8	3/8-16 HHCS x 1.25" Length
3	LWE156	8	3/8" External Tooth Lock Washer
4	LW156	8	3/8" Spring Lock Washer
5	HN146	8	3/8-16 Hex Nut

Notes :

- Splice requires holes drilled in Cable Rack Stringer.
- Hardware finish is zinc yellow.

Specifications subject to change. Please contact CSF Customer Service for more information.



SCE825 Rigid Cable Rack Splice for 1.50" and 2.00" Stringers

SCE825 - Rigid Cable Rack Splice for 1.50" and 2.00" Stringers

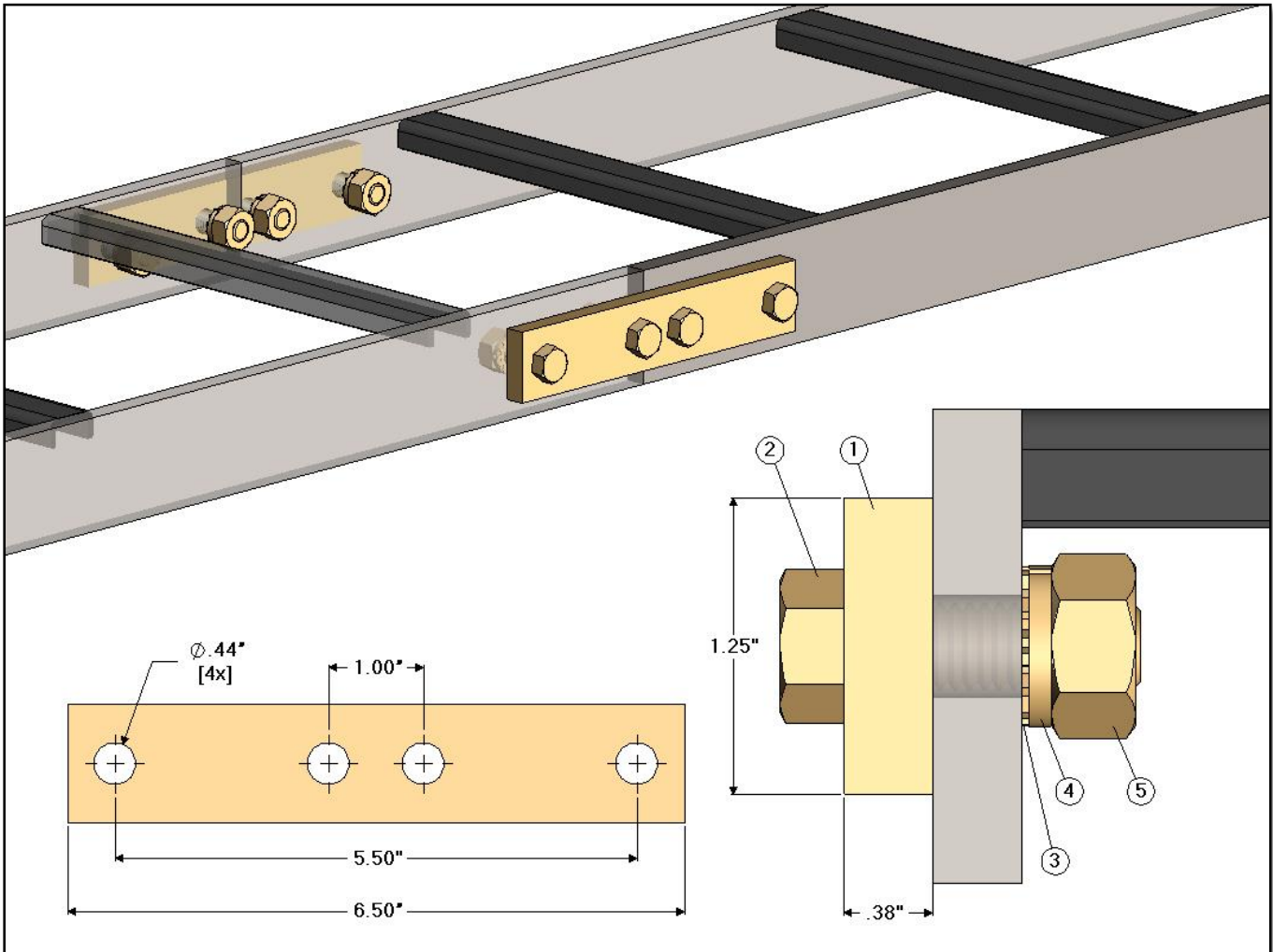

SCE825 - Rigid Cable Rack Splice for 1.50" and 2.00" Stringers

Item	CSF P/N#	QTY	Description
1	SCE650B	2	Splice Bar
2	HH1006	8	3/8-16 HHCS x 1.25" Length
3	LWE156	8	3/8" External Tooth Lock Washer
4	LW156	8	3/8" Spring Lock Washer
5	HN146	8	3/8-16 Hex Nut

Notes :

- Splice requires holes drilled in Cable Rack Stringer.
- Hardware finish is zinc yellow.

Specifications subject to change. Please contact CSF Customer Service for more information.